

8-2-1991

Campus News August 2, 1991

La Salle University

Follow this and additional works at: http://digitalcommons.lasalle.edu/campus_news

Recommended Citation

La Salle University, "Campus News August 2, 1991" (1991). *Campus News*. 394.
http://digitalcommons.lasalle.edu/campus_news/394

This Book is brought to you for free and open access by the University Publications at La Salle University Digital Commons. It has been accepted for inclusion in Campus News by an authorized administrator of La Salle University Digital Commons. For more information, please contact careyc@lasalle.edu.

CAMPUS NEWS

LA SALLE UNIVERSITY'S WEEKLY INFORMATION CIRCULAR

August 2, 1991

Attention Faculty:

As you plan for the Fall Semester, consider what library skills your students will need to be successful in your class.

The library is committed to an active role in helping students develop effective research skills. To fulfill this commitment

Bibliographic Instruction (BI) services are available to teach students about specific information sources and research strategies needed to complete an assignment or project.

A benefit of BI is that instructors can offer more varied assignments and students can get help with using information sources they never would have thought to use. BI is also a great way for new faculty to get acquainted with the library.

Reference librarians will be happy to teach a classroom session centered around the information needs of your students. If interested, give Bernetta Robinson a call at X1287. Early arrangements can help ensure your choice of date, time and use of the library classroom.

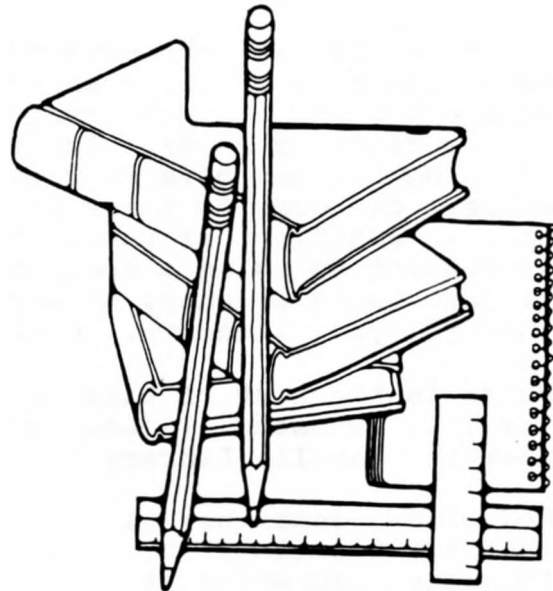

Campus News is distributed weekly to foster communication and encourage information sharing among University departments. Articles submitted are the responsibility of their authors alone and do not imply an opinion on the part of La Salle University or the Department of Mail and Duplicating Services.

To: All Faculty Members
From: Eithne Bearden, Online Services Coordinator, Connelly Library

Subject: Online Training Classes for your Students

If you would like the students in your classes to be able to take advantage of the over 400 databases in the Dialog Online System, it is important that they attend at least one online training class. Below is the schedule for the open training classes offered twice a week by the library. Any student can come to these classes; there is no need to sign up. In addition, if you would like to tailor a class assignment to using a specific database or databases, the library would be happy to set up a special training class just for your students. Contact Eithne Bearden at 951-1449

Below is the list of times for open training classes during the fall semester. (Students should come to the Information Desk in Connelly Library):

Wednesday, September 11	10:30 A.M.
Tuesday, September 17	2:30 P.M.
Thursday, September 19	5:15 P.M.
Sunday, September 22	2:30 P.M.
Tuesday, September 24	6:30 P.M.
Monday, September 30	5:15 P.M.
Saturday, October 5	2:30 P.M.
Wednesday, October 9	5:15 P.M.
Friday, October 11	1:30 P.M.
Tuesday, October 15	5:15 P.M.
Wednesday, October 16	3:30 P.M.
Sunday, October 20	2:30 P.M.
Thursday, October 24	5:15 P.M.
Monday, October 28	6:30 P.M.
Tuesday, October 29	10:30 A.M.
Monday, November 4	10:30 A.M.
Tuesday, November 5	5:15 P.M.
Saturday, November 16	2:30 P.M.
Wednesday, November 20	1:30 P.M.
Thursday, November 21	5:15 P.M.
Sunday, November 24	2:30 P.M.
Monday, December 2	11:30 A.M.
Wednesday, December 4	5:15 P.M.

NOTICE

To: The Campus Community
From: Susan M. Dunham
Director of Catering and Conferences
Re: Special Events Planning Workshop

.....
If you are the administrator, instructor , secretary or program assistant in charge of setting up special events, there will be a workshop offered on Wednesday, August 21, 1991 from 10am-11:30am in Union 301. The workshop is designed to assist you in all phases of the planning process.

AGENDA

- | | |
|-------------------|--|
| 10:00am-10:15am | Refreshments and Introduction of new Catering staff |
| 10:15am-11:15am | Presentation |
| | * Catering and Conferences
"What it is, What it's not.." |
| | * Guidelines for Bookings
"How To's" |
| | * '91/'92 Catering Menus |
| | * On Campus versus Off Campus
Group Bookings & Menu Pricing |
| | * New developments for the
Private Dining Room and
Faculty Dining Room |
| 11:15-11:30am | * Questions and Answers |
| *** 11:30-12:30pm | * For your convenience, Catering
personnel will be available to
take '91/'92 bookings! |

Please contact the Catering Department at Ext: 1419 or via E-Mail to reserve your space. We look forward to seeing you there!

Positions Available:



Resident Educator(Alcohol and Other Drug) - Resident Life. Major Areas of responsibility include counseling, educational programming, and consulting along with administering university policies. Seeking those with experience in alcohol/drug education and/or in a college housing staff position. Requires enrollment in a human/social services, addiction counselor, clinical psychology, etc., Philadelphia area graduate program. Compensation includes: apartment (live-in position), tuition remission, meal plan and cash stipend. Send cover letter, resume, and a list of three references to: Ann Isely, Assistant Director for Resident Life 818.

Student Loan Clerk - Student Loan Office. Responsibilities include processing applications, cash receipts, and loan collections. The position requires initiative, attention to detail, a mathematical aptitude, and light typing skills. A pleasant telephone manner and the ability to deal with the public are also necessary. Standard benefits package including tuition remission, paid vacation, and health insurance. Send resume and references to: Manager, Student Loans, Box 824.
EOE / AA

Building Blocks Child Development Center

***For children 15 months. - 5 years.
DPW Licensed - Hours 7:30 A.M. - 6:00 P.M.***

- * A supportive atmosphere for parents and children.
- * A diverse and multicultural learning environment.
- * State Certified Early Childhood Teachers.
- * Developmental Curriculum with Trips and Special Programs.

Call - 951-1573

